

PA-H8/325-68x Data Sheet

68 pin PLCC socket/28 pin DIP 0.6" plug

Supported Device/Footprints

These adapters allow EPROM programming of several Hitachi 68 pin H8/32x devices in their PLCC, CLCC or LCC packages on 28 pin DIP programmers.

Hitachi device part numbers **H8/322**, **H8/323** and **H8/325** program in the 27C256 28 pin DIP footprint.

These adapters are direct replacements for Hitachi programming adapters. See the following cross reference.

LSC adapter	Test skt	Device package	Hitachi adapter
PA-H8/325-68	Auto-Eject	PLCC and CLCC	HS328ESC01H
PA-H8/325-68Z	Lidded-ZIF	PLCC and CLCC. LCC with shim installed in socket	

Adapter Construction

The adapter is made up of 2 sub-assemblies. They assemble via connectors making the adapter modular. This way the sub-assemblies can be replaced easily.

When disassembling the adapter take care not to bend the pins. When reassembling the adapter note the pin 1 indicators to align the parts correctly.

The following chart shows the various socket and board part numbers that make up these adapters.

Adapter	Socket	Board
PA-H8/325-68	68-304	325-68
PA-H8/325-68Z	68-390	325-68Z

Adapter Dimensions

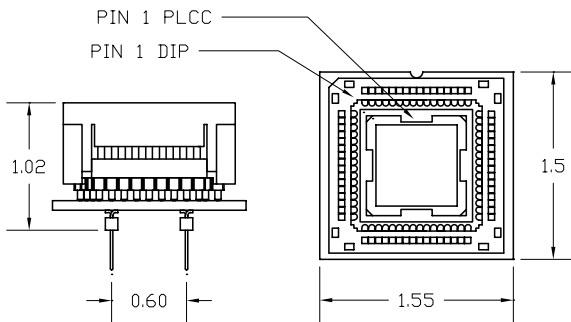

PA-H8/325-68

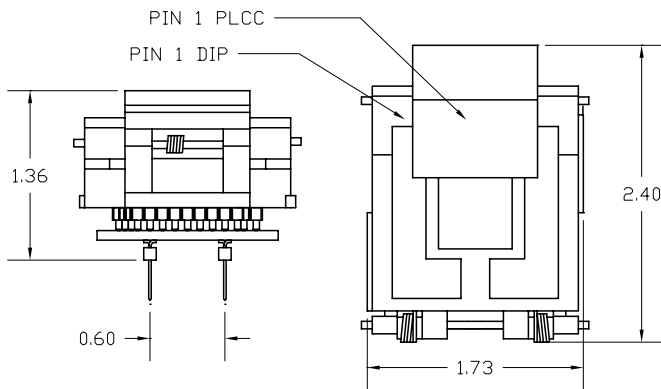

PA-H8/325-68Z

Test Socket

LSC #	Style	Mfgr/Pn
68-304	Auto-Eject	Yamaichi IC120-0684-304
68-390	Lidded ZIF	Yamaichi IC51-0684-390

Shims for the ZIF Socket

The ZIF socket will accept the LCC package as well as the PLCC and CLCC packages. Since the LCC package is thinner than the PLCC a shim must be installed in the ZIF socket to provide proper contact pressure.

LCC thickness varies. For any particular LCC package design, the shim thickness will need to be determined. The ZIF socket was designed to accommodate the PLCC package which is 0.170" +/- 0.005" thick.

If you need assistance with shims, please call us. We will be happy to help you out.

Adapter Wiring

The following chart shows the connections from the PLCC device to the adapter's DIP plug.

H8/32x device/socket pin					
DIP plug pins					
27c256 Signal					
9	1	VPP	VCC	28	33, 34, 15, 42
46	2	A12	A14	27	44
53	3	A7	A13	26	45
54	4	A6	A8	25	50
55	5	A5	A9	24	14
56	6	A4	A11	23	47
57	7	A3	OE*	22	49
58	8	A2	A10	21	48
59	9	A1	CE*	20	43
60	10	A0	D7	19	26
19	11	D0	D6	18	25
20	12	D1	D5	17	24
21	13	D2	D4	16	23
13, 12, 16, 17, 52	14	GND	D3	15	22

All other PLCC pins are not connected.

EPROM Address Mapping

The H8's EPROM is at the same address for MCU mode (normal execution) and EPROM programming. The valid EPROM addresses for each device are as follows.

Device	EPROM size	EPROM addresses	MCU addresses
H8/322	8K bytes	0000-1FFF	0000-1FFF
H8/323	16K bytes	0000-3FFF	0000-3FFF
H8/325	32K bytes	0000-7FFF	0000-7FFF

LOGICAL

Logical Systems Corporation
 PO Box 6184, Syracuse, NY 12817-6184 USA
 Tel (315) 478-0722, FAX (315) 479-6753
 S Y S T E M S www.logicalsyst.com, Email: info@logicalsyst.com

H8/325-68x Data Sheet
 Doc: H8325-68.DOC
 Rev 03/06/01
 Page 1 of 1